

K₂SO₄ production from MgSO₄

Reaction equations

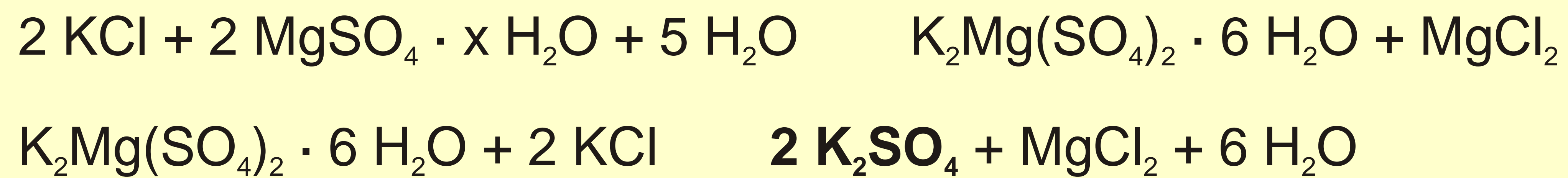

Main Process Steps:

Two — Step — Conversion (t = 25 °C)

Magnesium Sulphate + Sylvite Schoenite SOP

Process flow sheet

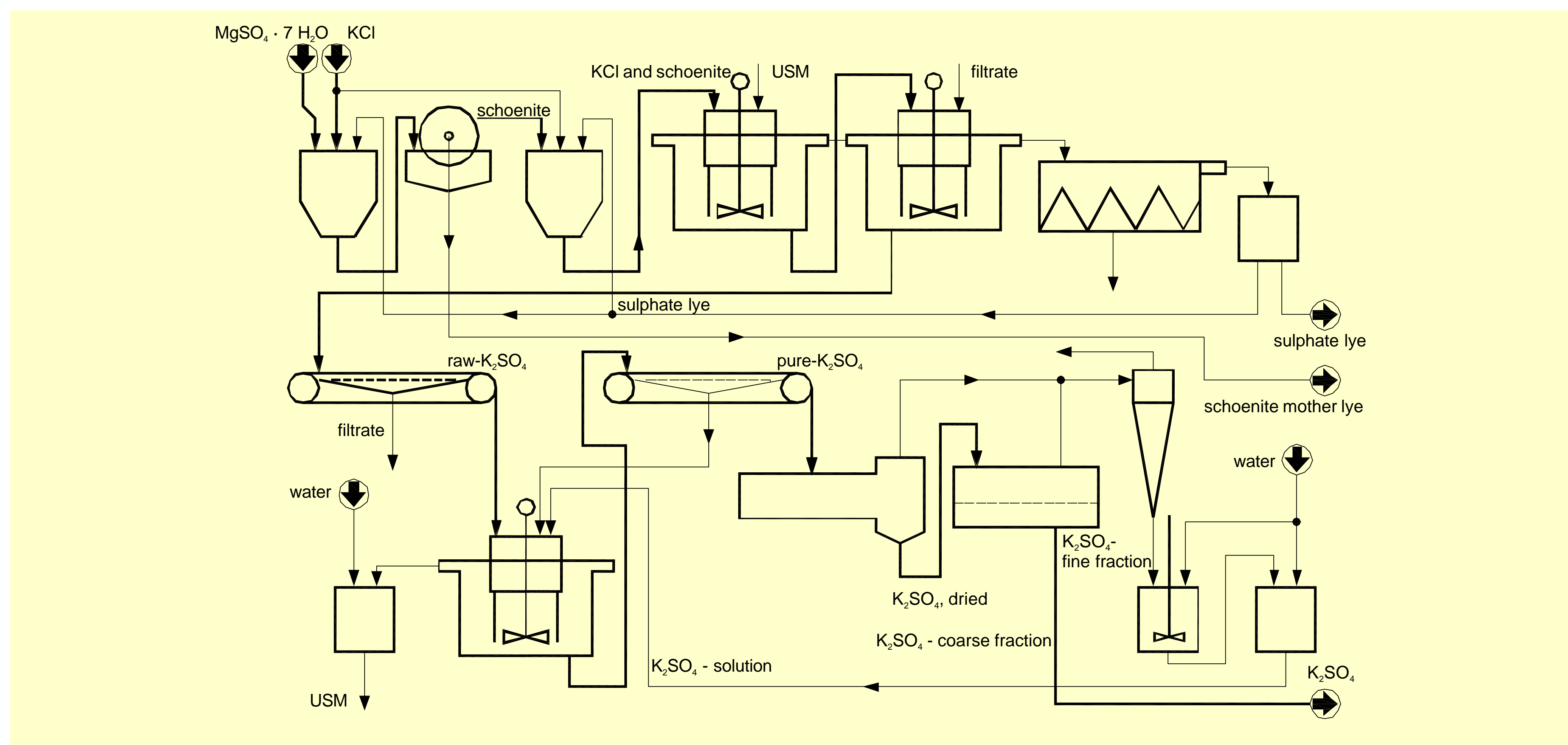

CONTACT:

Kali-Umwelttechnik GmbH • Am Petersenschacht 7 • 99706 Sondershausen • Germany
Phone 0049-03632-610 0 • Fax 0049-03632-610 105 • e-mail kutec@kutec.de • internet <http://www.kutec.de>